

Español Americano Latino

Para obtener este manual en Español Latino Americano vaya a: <http://support.nautilus.com>.

Important Safety Instructions - Before using this equipment, obey the following warnings:



This icon means a potentially hazardous situation which, if not avoided, could result in death or serious injury. Read and understand all Warnings on this machine.

- Keep children away from this machine. Monitor them closely when near the machine. Moving parts that look dangerous to adults may not look so to children.
- Consult a physician before starting an exercise program. Stop exercising if you feel pain or tightness in your chest, become short of breath, or feel faint. Contact your doctor before using the machine again.
- Examine this machine for loose parts or signs of wear. Tighten or replace any worn or loose components before use. Examine all fasteners carefully. Contact Nautilus® Customer Service for repair information.
- This machine is for home use only.
- Set up and operate bench on a hard, level surface.
- Do not wear loose clothing or jewelry while exercising.
- Keep your body weight centered on the bench while exercising.
- Fully attach Back Support before use.
- Maximum user weight limit: 250 lbs (113.4 kg). Do not use if you are over this weight.
- Maximum lifting load limit: 180 lbs (81.6 kg).
- Keep at least 50" (1.3 m) clear on each side of the bench. This is the recommended safe distance for access and passage around the bench.
- Do not exercise with more resistance than you can physically handle. We recommend you train with an exercise partner or spotter.
- This product, its packaging, and components contain chemicals known to the State of California to cause cancer, birth defects, or reproductive harm. This Notice is provided in accordance with California's Proposition 65. If you would like additional information, please refer to our Web site at www.nautilus.com/prop65.

Nautilus, Inc., World Headquarters, 16400 SE Nautilus Dr. Vancouver, WA, USA 98683, (800) NAUTILUS / (800) 628-8458, www.NautilusInc.com - Customer Service: North America (800) 605-3369, CSNLS@nautilus.com | Europe, Middle East & Africa 49 02203 2020 0, technics-EMEA@nautilus.com | Germany & Austria + 49 02203 2020 0, Switzerland + 41 26 460 77 66, United Kingdom + 44 1908 267 345, Asia Pacific & Latin America (360) 859-5180, technics-APLA@nautilus.com | Patent information: This product may be covered by U.S. and Foreign Patents and Patents Pending. See Product for more information. | Made in China | © 2009 Nautilus, Inc., All rights reserved. ™ and ® indicate a trademark or registered trademark. Nautilus, Inc. (www.nautilus.com) trademarks include NAUTILUS®, BOWFLEX®, SCHWINN® and UNIVERSAL® and respective logos. Other trademarks are the property of their respective owners.

To register your product for Warranty support please visit: www.UniversalHomeFitness.com/Register

To validate warranty support record the following information: Serial Number _____ Date of Purchase _____

Assembled Unit Weight: 33.4 lbs / 15.15kg

Maintenance

The safety and performance of this product can be maintained only if it is examined regularly for damage and wear.



Examine the equipment before each use for damage and wear. Replace broken components immediately or put the equipment out of use until repaired.

Daily/Before Each Use: Examine machine. Make sure it looks in good condition and operates smoothly. If you find damage, DO NOT USE. Contact your authorized Nautilus® Fitness Dealer for servicing.

Daily/After Each Use: Clean machine with a clean, dry cloth. Use a mild detergent or spray cleaner on upholstery. Do not use cleansers containing enzymes.

Weekly: Clean machine fully with a clean cloth and ammonia-based cleaner. Touch up any scratches with touch-up paint to prevent rust, if necessary.

Monthly: Examine the frame for signs of cracking or permanent bending. Do not use the equipment if you see this. Contact Nautilus® Service immediately.

If you have any questions on the correct use or maintenance of this equipment, call your authorized distributor or Nautilus Customer Service at 1-800-NAUTILUS (628-8458). Only Nautilus®-trained or Nautilus®-authorized personnel should make extensions, readjustments, modifications, or repairs.

Tools (included)

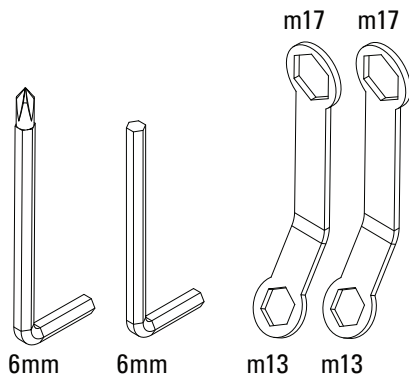

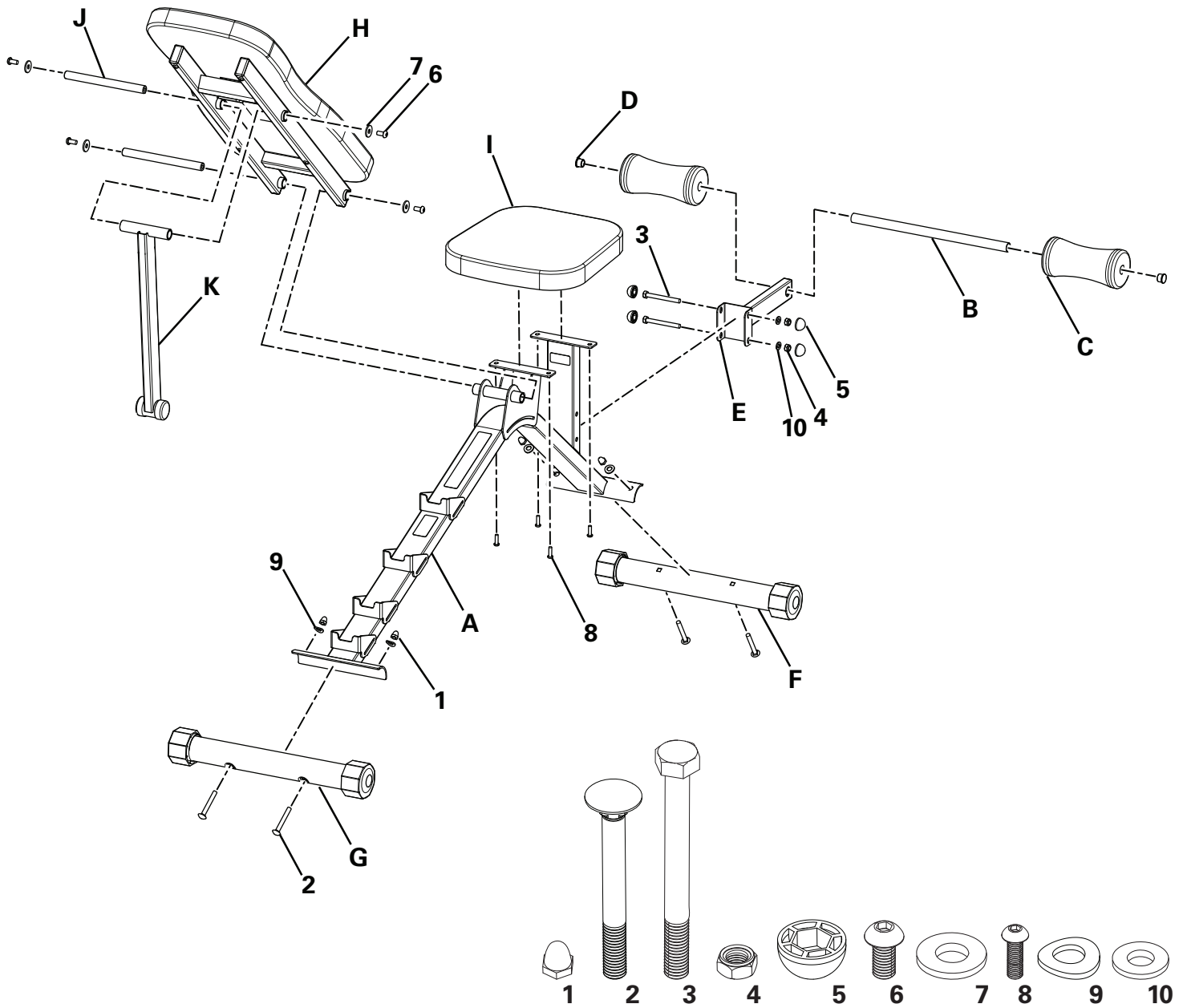

Item	Qty	Description
A	1	SPINE ASSEMBLY
B	1	ROLLER TUBE - UB300
C	2	ROLLER PAD
D	2	ROLLER END CAP
E	1	LEG HOLD DOWN ASSY UB300
F	1	FRONT STABILIZER UB300 (with decal)
G	1	REAR STABILIZER UB300
H	1	SEAT BACK ASSEMBLY
I	1	SEAT
J	2	PIVOT AXLE
K	1	ADJUSTABLE ARM ASSEMBLY

Item	Qty	Description
1	4	ACORN NUT M10X1.5
2	4	CARRIAGE BOLT M10X60
3	2	HEX HEAD CAP SCREW M8X75
4	2	NUT NL M8-1.25 G2 ZINC
5	4	NUT CAP
6	4	BUTTON HEAD CAP SCREW M10X20
7	4	FLAT WASHER M10
8	4	BUTTON HEAD CAP SCREW M6X20
9	4	CURVED WASHER M10
10	2	FLAT WASHER M8

Inspect your machine to ensure that all fasteners are tight and components are properly assembled.

! Do not use or put the machine into service until the machine has been fully assembled and inspected for correct performance in accordance with the Owner's Manual.